

THIS DRAWING IS UNPUBLISHED. RELEASED FOR PUBLICATION SEPT ,2005.

© COPYRIGHT 2005 BY TYCO ELECTRONICS CORPORATION. ALL RIGHTS RESERVED.

LOC	DIST	REVISIONS					
E	B	P	LTR	DESCRIPTION	DATE	DWN	APVD
		E		ECR-05-015561	14NOV05	JMS	FWK

NOTES:

- ① SINGLE PACK IN ACCORDANCE WITH AMP SPEC 107-3275
- ② 100 TRAY PACK IN ACCORDANCE WITH AMP SPEC 107-3275
- ③ FLASH Au PLATING
- ④ 0.8µm Au PLATING
- ⑤ Ni PLATING
- ⑥ THIS ITEM MUST BE WHITE
- 7. HAND TOOL : 9-1478240-0
- 8. DIE SET : 9-1478242-0
- 9. ELECTRICAL CHARACTERISTICS
 FREQUENCY RANGE: DC - 4 GHz
 NOMINAL IMPEDANCE: 50 Ohm
 INSULATION RESISTANCE: 5000 MOhm
 WORKING VOLTAGE: 500 Volts RMS at Sea Level
 DIELECTRIC WITHSTAND VOLTAGE: 1500 Volts RMS Max
 CONTACT RESISTANCE:
 CENTRE CONTACT: 1.50 mOhm Max
 OUTER CONTACT: 0.20 mOhm Max
 VSWR @ 4GHz: 1.30:1 Max
 INSERTION LOSS dB @ x 3 GHz: 0.20 Max
- 10. MECHANICAL CHARACTERISTICS
 COUPLING NUT RETENTION FORCE: 445N Min
 CABLE RETENTION FORCE: 170N Min
 DURABILITY: 500 Cycles Min
- 11. ENVIRONMENTAL CHARACTERISTICS
 OPERATING TEMPERATURE: -65 to +165 DegC

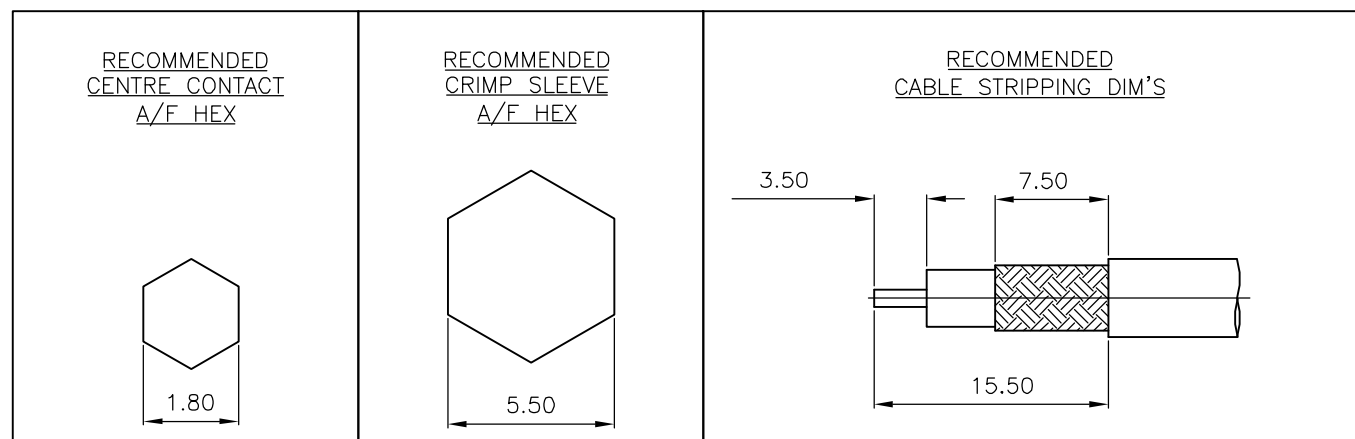
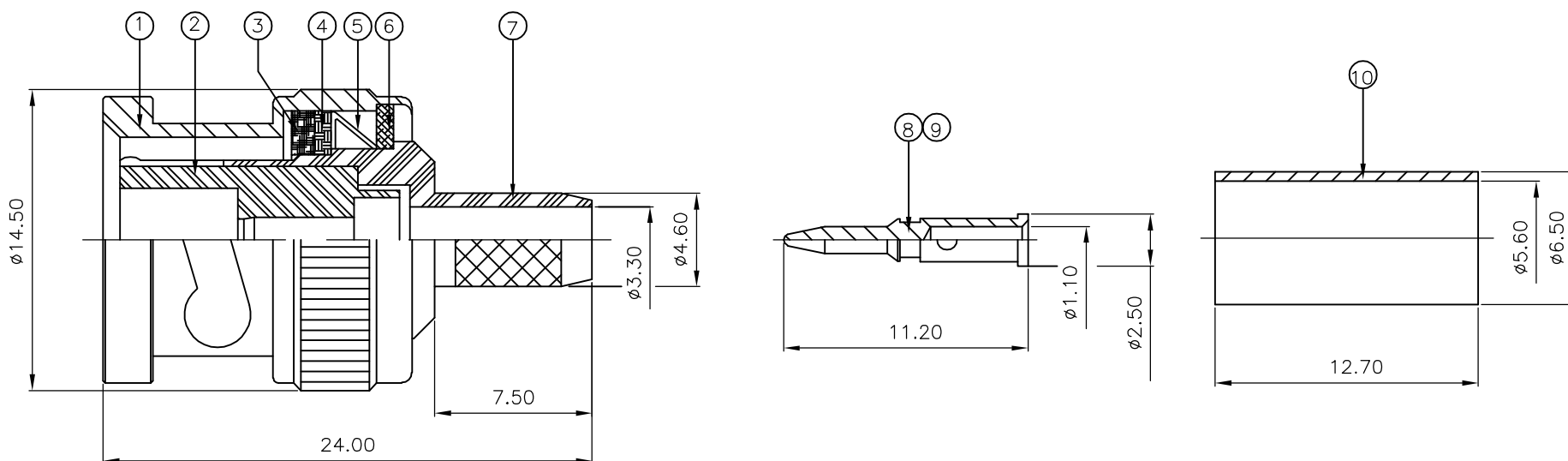

QTY	PLC	QTY	PLC	MATERIAL	DESCRIPTION	ITEM
1	1	1	1	BRASS	FERRULE	10
1	1	-	-	BRASS	CONTACT	9
-	-	1	1	BRASS	CONTACT	8
1	1	1	1	BRASS	BODY	7
1	1	1	1	BRASS	WASHER	6
1	1	1	1	SPRING STEEL	SPRING	5
1	1	1	1	BRASS	WASHER	4
1	1	1	1	SILICON RUBBER	GASKET	3
1	1	1	1	PTFE	INSULATION	2
1	1	1	1	BRASS	SHELL	1
6--1	1--1	6--0	1--0	MATERIAL	DESCRIPTION	ITEM

THIS DRAWING IS A CONTROLLED DOCUMENT.		DWN J.SANDWELL 12SEPT05	Tyco Electronics Corporation Bideford, UK, EX39 4HE	
DIMENSIONS: mm		CHK S.PARLOW 12SEPT05		
TOLERANCES UNLESS OTHERWISE SPECIFIED:		APVD F.WHEELER-KING 12SEPT05	NAME BNC STRAIGHT PLUG CRIMP 50 OHM RG58C/U, 141A/U, URM 43 & 76, KX15 BELDEN 9907	
0 PLC ± - 1 PLC ± - 2 PLC ± - 3 PLC ± - 4 PLC ± - ANGLES ± -		PRODUCT SPEC 108-3435	DRAWING NO A3 00779 C-1337426	
MATERIAL SEE TABLE		APPLICATION SPEC 411-3247	RESTRICTED TO -	
FINISH SEE TABLE		WEIGHT -	SCALE NTS	
CUSTOMER DRAWING		SHEET 1 OF 1		REV E